



GN III AND GN III/ST CALIPER

with 3.50" MOUNTING TABS

Caliper Highlights:

Wilwood's GN III is a time proven caliper that has been widely used with 5 on 5 hubs for stock car, road course, and off-road competition. The 3.50" mount configuration incorporates this legacy of enduring performance, with options available for the latest brake system heat management technology.

3.50" mount with taller height for 12.19" rotors. The new generation GN III uses the same popular 3.50" mounting pattern found on the Superlite caliper series, but are built with a taller mounting height. This feature accommodates the installation of 12.19" diameter rotors on the same spindle brackets used with a Superlite caliper and 11.75" diameter rotor. The GN III can be run with either a 1.25" or 1.38" thick rotor. This makes it possible to run three different bolt-on brake setups, without the need for bracket changes on the spindle.



High strength, low deflection, and superior stopping power. Each GN III is manufactured from a precision casting using a tight grained, high-density aircraft alloy. It is a two piece, closed bridge design with grade 8 thru-bolts and external stiffening ribs. The GN III utilizes a unique six-piston configuration that generates high clamping force with balanced loading for extremely even pad wear. The 1.75" / 1.38" / 1.38" bore pattern contains a total of 5.44 square inches of effective piston clamp area. This makes the GN III one of the largest calipers available. The caliper bridges are fitted with stainless steel plates to reduce wear and provide the smoothest pad operation. Dual center bridge bolts add to the overall caliper strength and provide positive retention for the top loaded pads. Dollar for dollar, this combination is unmatched for high strength, low deflection, and superior stopping power.

Thermlock® or stainless steel pistons. The standard GN III uses six stainless steel cup pistons. Stainless is used for its slow heat transfer properties and high corrosion resistance. The GN III/ST models feature Wilwood's exclusive Thermlock® pistons to minimize the direct heat transfer from the pads. These pistons can reduce caliper temperatures by more than 30% over stainless steel pistons, without the need for fluid recirculation systems. Fluid temperatures are reduced, seal life is extended, and caliper service life is prolonged with less distortion and reduced wear in the piston bores. Cooler temperatures translate into maximum performance and ultimate reliability over the longest run. Using EXP 600 Plus racing brake fluid will guarantee success with trouble free performance in all extreme conditions.

Big pad volume. The 3.5" mount GN III calipers use the same 7520 style pad as the traditional GNIII caliper. The longer and wider pad face provides a full two cubic increase in pad volume over a 7320 style Superlite pad. Larger pads mean longer wear and additional heat resistance in extreme duty conditions. Six PolyMatrix compounds are available to match brake torque and heat range requirements on any application.

ORDERING INFORMATION: CALIPERS:

GN III/ST CALIPERS, 3.50" MOUNT WITH THERMLOCK® PISTONS

BORE SIZE	DISC WIDTH	FRONT MOUNT PART NUMBER		REAR MOUNT PART NUMBER	
		RH	LH	RH	LH
1.75/1.38/1.38 47,8/44,5/44,5 mm	1.25" - 1.38" 31,8 - 35.1 mm	120-6951-FS	120-6952-FS	120-6951-RS	120-6952-RS

GN III CALIPERS, 3.50" MOUNT WITH STAINLESS STEEL PISTONS

1.75/1.38/1.38 47,8/44,5/44,5 mm	1.25" - 1.38" 31,8 - 35.1 mm	120-6478-FS	120-6479-FS	120-6478-RS	120-6479-RS
-------------------------------------	---------------------------------	-------------	-------------	-------------	-------------

GN III CALIPER, MOUNTING DIMENSIONS:

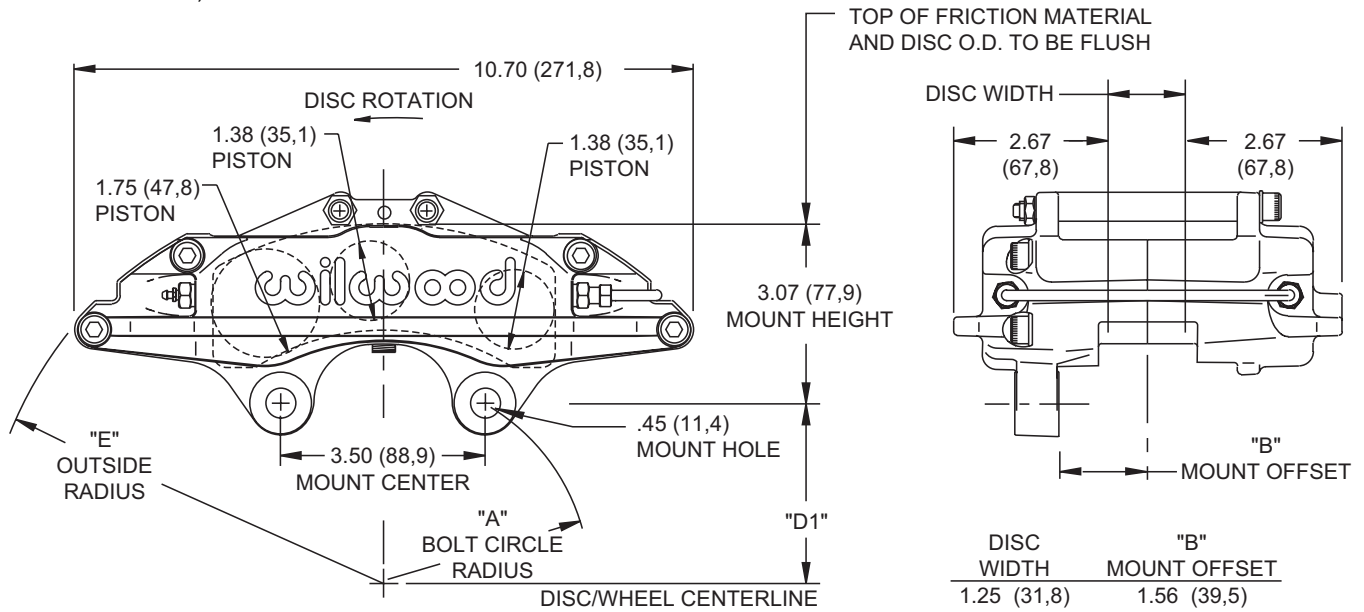

DIMENSION "D1" = (DISC DIAMETER/2) - 3.07 (77,9)

NOTE:
RIGHT HAND, REAR MOUNT CALIPER SHOWN
INLET FITTING: 1/8-27 NPT

DISC DIAMETER	"A" BOLT CIRCLE RADIUS	"E" OUTSIDE RADIUS
12.19 (309,6)	3.50 (88,9)	6.92 (175,8)

GN III CALIPER, TYPE 7520 PAD DIMENSIONS AND ORDERING INFORMATION:

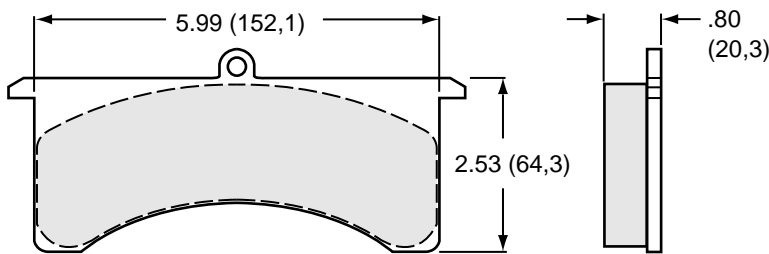

AXLE SET PART NO.	PAD TYPE/COMPOUND
15A - 5736K	7520 A PolyMatrix
15B - 3993K	7520 B PolyMatrix
15C - 4041K	7520 C PolyMatrix
15D - 4333K	7520 D PolyMatrix
15E - 6101K	7520 E PolyMatrix
15Q - 6879K	7520 Q PolyMatrix

ORDERING INFORMATION: USER SERVICEABLE COMPONENTS:

ASSEMBLY	INBOARD BODY	OUTBOARD BODY	PISTON	PAD WEAR PLATE (EA)	CROSSOVER TUBE (4 PK)	COTTER PIN KIT (10 PK)	BLEED SCREW KIT (4 PK)	BRIDGE BOLT KIT	SQ RING KIT (6 PK)
120-6478-FS	110-6476	110-3026	200-3176 (1.38") 200-3062 (1.75")	300-3053	190-3664	180-0053	220-0627	230-3029	130-3084
120-6478-RS	110-6476	110-3026	200-3176 (1.38") 200-3062 (1.75")	300-3053	190-3664	180-0053	220-0627	230-3029	130-3084
120-6479-FS	110-6477	110-3028	200-3176 (1.38") 200-3062 (1.75")	300-3053	190-3664	180-0053	220-0627	230-3029	130-3084
120-6479-RS	110-6477	110-3028	200-3176 (1.38") 200-3062 (1.75")	300-3053	190-3664	180-0053	220-0627	230-3029	130-3084
120-6951-FS	110-6476	110-3026	200-5407 (1.38") 200-5399 (1.75")	300-3053	190-3664	180-0053	220-0627	230-3029	130-3084
120-6951-RS	110-6476	110-3026	200-5407 (1.38") 200-5399 (1.75")	300-3053	190-3664	180-0053	220-0627	230-3029	130-3084
120-6952-FS	110-6477	110-3028	200-5407 (1.38") 200-5399 (1.75")	300-3053	190-3664	180-0053	220-0627	230-3029	130-3084
120-6952-RS	110-6477	110-3028	200-5407 (1.38") 200-5399 (1.75")	300-3053	190-3664	180-0053	220-0627	230-3029	130-3084