

REAR SUPERLITE 4 BIG BRAKE KITS FOR 2009-2013 HYUNDAI GENESIS COUPE

Models Covered:

- 2009 - 2013 Hyundai Genesis Coupe

Kit Features:

- Upgrade from OE calipers to Forged Billet Narrow Superlite 4 Radial Mount four piston calipers for either street or track.
- Choose either 12.88" diameter GT slotted or SRP drilled and slotted **Spec 37** material rotors.
- Simple bolt-on installation with minor modifications required.
- Fully compatible with ABS and OE master cylinder output.

Component Features:**FNSL4R Radial Mount Four Piston Calipers**

- Competition proven forged billet aluminum bodies demonstrate superior strength and resistance to deflection and separation under high load.
- Four symmetrical bore stainless steel pistons generate high clamping force for optimized stopping power. Stainless steel pistons stay corrosion resistant and inhibit heat transfer from the pads to the caliper body, fluid and seals.
- The internal piston seal-in-bore design adds proven durability with keeping the fluid in and dirt out without the need for external boot seals.
- For more aggressive race applications, calipers can be fitted with our exclusive Thermlock pistons which provide the most effective thermal barrier for minimizing heat transfer from the brake pads to the caliper body, seals, and fluid.
- Spring loaded stainless steel SRS bridge plates dampen pad noise and protect the caliper bridges from wear.
- Calipers provide easy access to the pads for service, without the need to unbolt the calipers from their mounts.
- Calipers are available with either black or red high-gloss, high temperature, brake fluid resistant sealed powder coat and feature Wilwood's signature logo.



FNSL4R Rear Kit Assembly
To Download High Res Photo,
[Click Here](#)

GT or SRP Series Spec 37 Compound 12.88" x .81" Rotor Options

- **Spec 37** rotors are manufactured from a proprietary iron alloy developed to withstand extreme temperatures with the highest possible degree of resistance against distortion, warping, cracking, and wear. The formulation for this alloy is a derivative of technology and materials that were significant in the development of the extreme duty military rotors that are manufactured by Wilwood.
- GT competition series rotors feature full detail machining with asymmetrical slots in the faces. GT rotors provide the highest degree of durability and longer life for repeated hard braking and high temperature use.
- Drilled rotor kits feature our signature SRP performance drilled and slotted rotors with a durable e-coat finish. E-coat seals the casting and prevents corrosion in all areas of the rotor not swept clean by the brake pads. This durable finish will maintain the high tech styling and appearance of the rotors inside your wheels for many miles down the road.

Iron Hats

- The specially machined iron hats bolt to the rotors and contain the drums for operation with the OE parking brake assembly.
- Black E-coat finish resists corrosion while adding to the aggressive competition look inside the wheel.

Wilwood "Smart Pads"

- Kits include our proven formula BP-10 Smart Pads. BP-10 is a unique composite-metallic compound that provides increased friction, stopping power, and higher fade resistance in a clean and quiet running low dust style pad.
- Optional high-temp and race only pad compounds are also available.

Radial Mounting Brackets, Hardware and Plumbing

- Radial mounting provides secure attachment directly to the OE mounts, with two planes of adjustment for precise alignment of the caliper over the rotor. Brackets, premium grade fasteners and alignment shims are included in each kit.
- Jacketed stainless steel braided, DOT approved flexline kits are included with each brake kit.

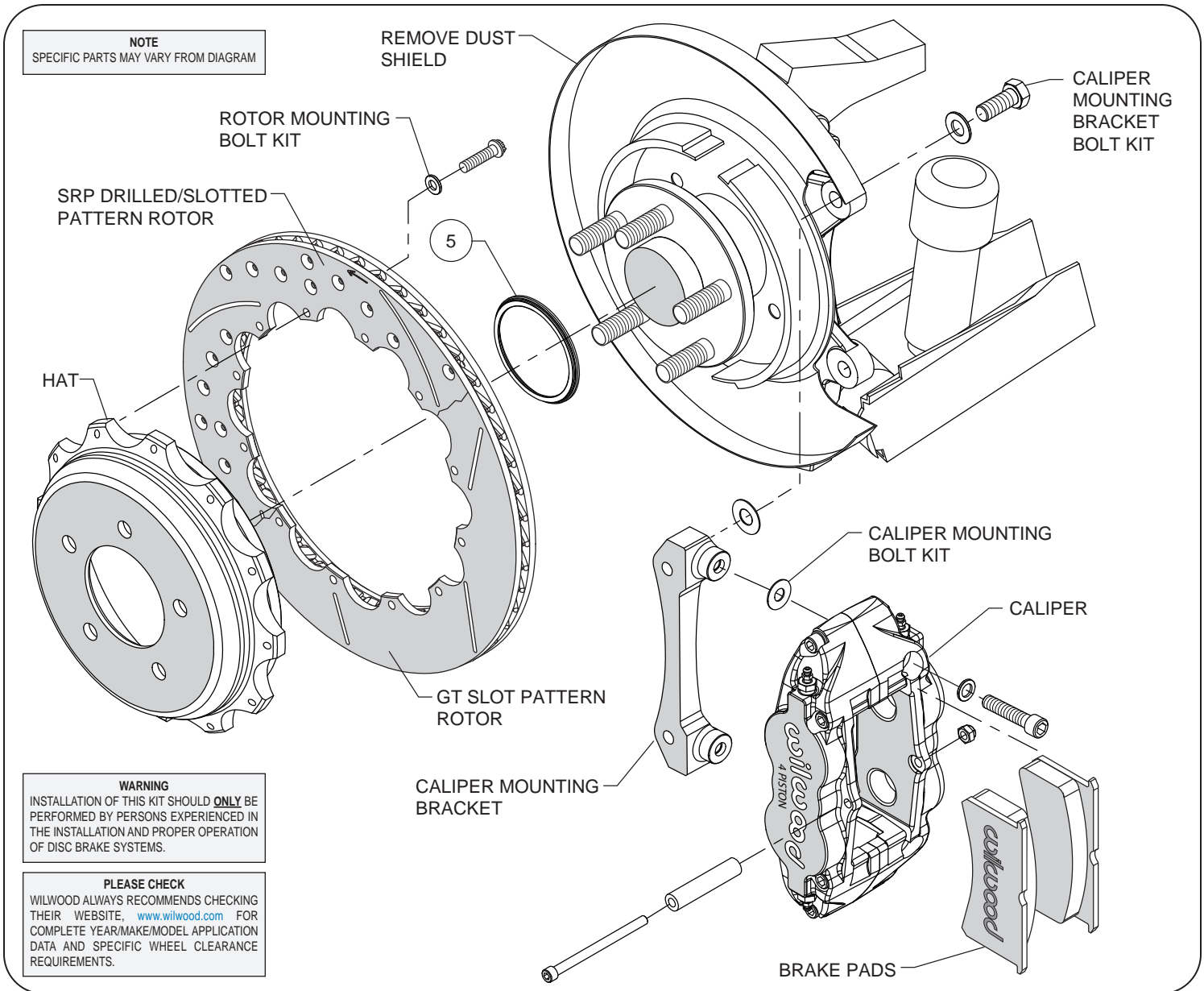

Typical Installation Diagram

ORDERING INFORMATION:

PART NUMBER	DESCRIPTION
140-13045	Rear Kit, Hyundai Genesis Coupe, FNSL4R Caliper, 12.88" GT Rotor, Black Caliper
140-13045-D	Rear Kit, Hyundai Genesis Coupe, FNSL4R Caliper, 12.88" SRP Drilled and Slotted Rotor, Black Caliper
140-13045-R	Rear Kit, Hyundai Genesis Coupe, FNSL4R Caliper, 12.88" GT Rotor, Red Caliper
140-13045-DR	Rear Kit, Hyundai Genesis Coupe, FNSL4R Caliper, 12.88" SRP Drilled and Slotted Rotor, Red Caliper



Need additional information - fast? Utilizing your Smartphone, scan the image at the left to jump to our web site. This code takes you to our home page and social media sites where information is just a click away, [or click here.](#)