

# **DYNALITE PRO SERIES FRONT HUB KIT FOR 1965-1966 4-LUG FORD MUSTANG**

## **Kit Features:**

- Designed specifically for the four lug, six cylinder (will not fit V8, 5 lug) first generation Mustang.
- Upgrade from OE calipers to billet forged 4-piston Dynalite calipers available in black anodized or red powder coat finish.
- 10.75" diameter ULHP plain face vented rotor.
- Optional DOT approved stainless steel flexline kit available in various lengths for a custom installation.
- Fully compatible with OE master cylinder output.
- BP-10 street performance brake pads standard.

## **Component Features:**

### **Forged Billet Dynalite Lug Mount Calipers**

- Calipers provide big clamping power in a truly lightweight, rigid and reliable design.
- Four stainless steel pistons provide additional corrosion resistance and the lowest heat transfer of any one-piece piston design.
- Black anodized finish provides excellent corrosion resistance and long term preservation of their high-tech style and appearance.
- Calipers are also available in a red powder coat finish.

### **ULHP 30 Vane 10.75" Rotors**

- Ultra-light straight rotors provide high performance and rugged durability for a wide range of competition, performance, and sport driving applications.
- Rotors are cast from premium grade, long grain carbon iron.

### **Forged Aluminum Hubs and Hats**

- Forged and fully machined billet hubs, with 1/2-20 grade 8 wheel studs mount to the OE spindle using preinstalled tapered roller bearings and races.
- Black anodized forged aluminum rotor mount hats help reduce weight and resist corrosion while adding to the aggressive competition look inside the wheel.

### **Wilwood "Smart Pads"**

- Kit includes BP-10 metallic-composite compound "Smart Pads". BP-10 delivers the increased friction; higher fade resistance, and longer wear of an entry-level track pad, with virtually noise and dust free performance for the street.
- Optional race-only compounds can be ordered to suit the braking requirements at all levels of severe duty and sustained high heat competition.

### **Brackets, Hardware, and Plumbing**

- Installation is simple. The kit is a complete bolt-on without the need to modify any of the existing brake or suspension components. Aluminum mounting brackets and premium grade hardware are supplied with detailed installation instructions in every kit.
- Stainless steel braided competition flexline kits are required to connect the Wilwood calipers to the brake system and must be ordered separately.



**Pro Series Front Kit with ULHP  
Rotor and Red Caliper**

Download High Resolution Photo,  
[click here](#)

**WARNING**  
 INSTALLATION OF THIS KIT SHOULD **ONLY** BE PERFORMED BY PERSONS EXPERIENCED IN THE INSTALLATION AND PROPER OPERATION OF DISC BRAKE SYSTEMS.

**NOTE**  
 SPECIFIC PARTS MAY VARY FROM DIAGRAM

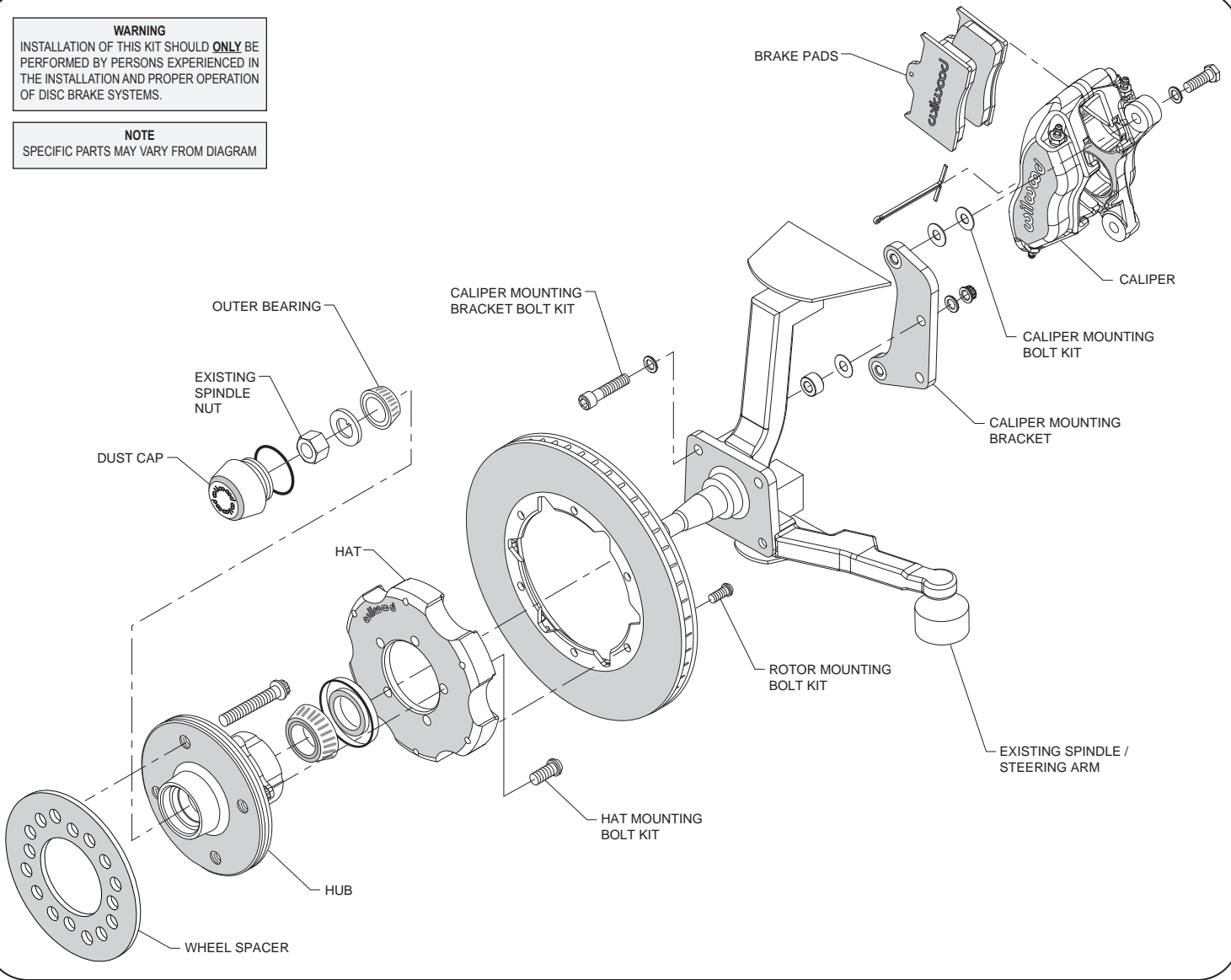

**Typical Installation Diagram**

**ORDERING INFORMATION:**

**PART NUMBER**

**DESCRIPTION**

140-12535	Front Kit, 1965-66 4 Lug Mustang, Dynalite Caliper, 10.75" ULHP Plain Face Rotor, Black Caliper
140-12535-R	Front Kit, 1965-66 4 Lug Mustang, Dynalite Caliper, 10.75" ULHP Plain Face Rotor, Red Caliper



Need additional information - fast? Utilizing your Smartphone, scan the image at the left to jump to our web site. This code takes you to our home page and social media sites where information is just a click away, [or click here.](#)