



1971-1974 AMC DYNAPRO LOW-PROFILE PARKING BRAKE KIT WITH 11.00" DIAMETER VENTED ROTOR

Models Covered:

Kit has been specifically designed to fit 1971-1974 AMC's

Kit Highlights:

- This Wilwood Pro Series rear disc brake kit with internal parking brake solves the problems associated with smaller diameter wheel clearances.
- Based on an 11.00" diameter rotor, coupled with our new DynaPro Low-Profile caliper gives you the option of a complete four piston disc brake kit with a fully functioning parking brake for 14 and 15 inch rim use.
- Easy bolt-on installation, kits include everything necessary for a simple installation.
- Compatible with OE and aftermarket disc brake master cylinders.
- It's the ultimate look in contemporary hot rod style with unmatched performance from race-born track ready components.

Component Features:

Forged Billet DynaPro Low-Profile Calipers

- Four stainless steel pistons generate high clamping force and balanced pad loading with low heat transfer and high resistance to corrosion.
- Spring loaded stainless steel SRS bridge plates reduce noise by dampening engagement harmonics and eliminating pad rattle. SRS plates also extend caliper service life by eliminating bridge gouging at the pad trailing edge.
- Top loaded pads are easily inspected and serviced without the need to remove the caliper from the mount.
- Standard kit includes black anodized calipers. Optional red or powder coat is also available.

SRP or ULHP Series 11.00" Diameter Rotors

- For cool running and increased stopping power, each kit includes 11.00" diameter vented iron alloy brake rotors with integral hats.
- Standard kits include smooth face ULHP rotors.
- Optional SRP directional drilled and slotted rotors enhance pad performance with consistent response by cleaning and venting gasses, dust, and burnt pad material. A black E-coat finish is applied to resist corrosion and preserve the aggressive high-tech look inside the wheel.

Wilwood BP-10 Compound High Performance "Smart Pads"

- BP-10 is an exclusive Wilwood metallic composite compound. This remarkable material possesses the quiet, low dusting properties found in ceramic based street compounds, but with the higher friction, heavier load capacity, and increased fade resistance of a medium range race pad.

Internal Shoe Parking Brake

- The drum style internal parking brake provides outstanding holding power with the ultimate uncluttered custom look.
- The two shoe system is mechanically actuated and spring loaded for quiet non-rattling performance.
- Brake shoes are neatly hidden and out-of-sight inside the rotor assembly. Parking brake cables are relocated inward with more clearance for deep offset wheels.

Mounting Brackets and Hardware

- Integral mounting brackets secure the caliper and the parking brake assembly to the axle tube.
- High strength steel and performance grade nuts, bolts, and alignment shims are include to complete the secure and accurate installation.

Note:

- Clevis and cable kits, which attach to the parking brake assembly are not included in the Wilwood parking brake kit. Wilwood offers a cable kit specifically for this vehicle, order part number 330-11954. Please visit our web site at www.wilwood.com, or call (805) 388-1188 for additional information.



Rear Parking Brake Kit with SRP Rotor

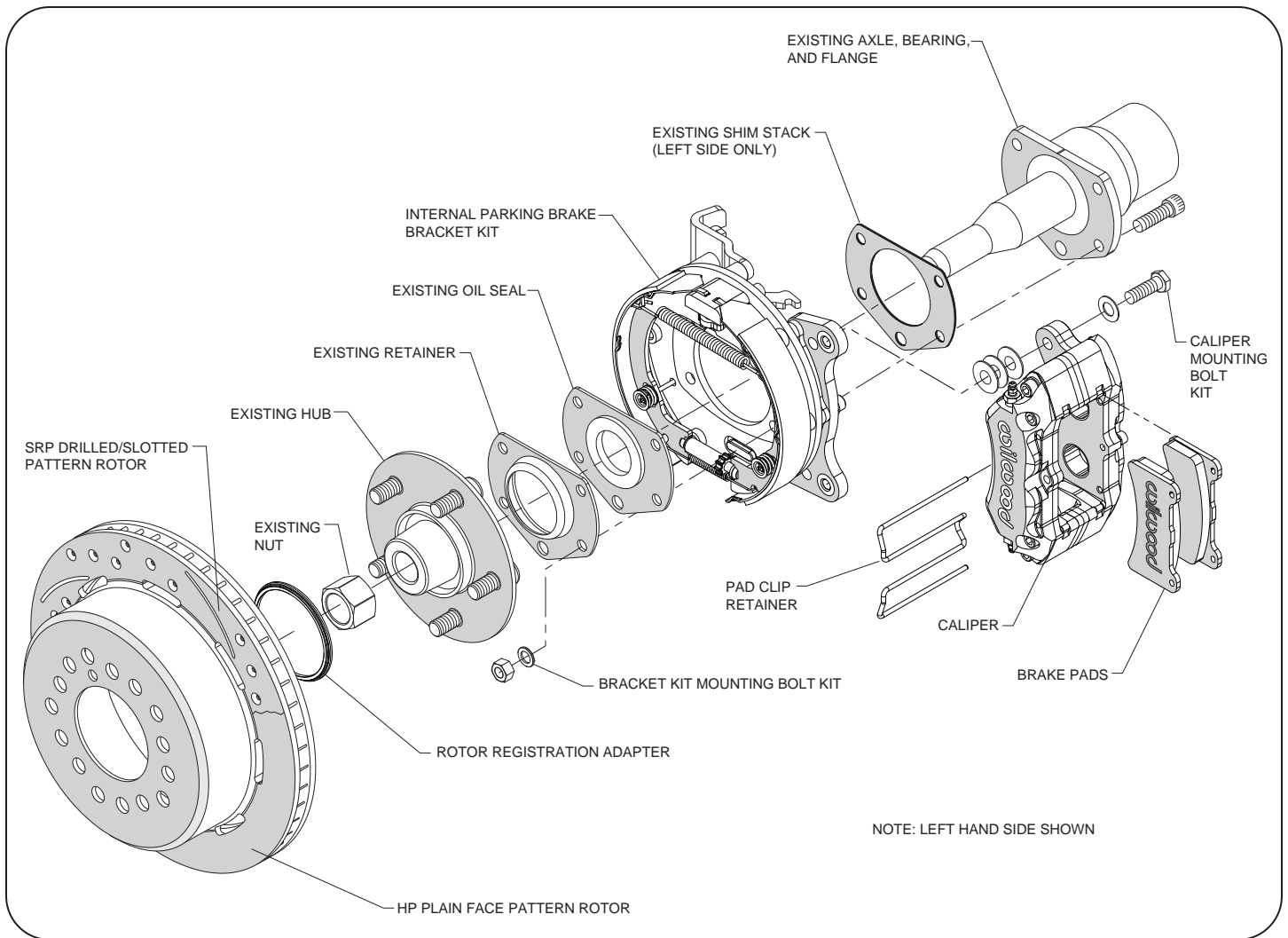

Typical Installation Diagram, Major Components Identified

ORDERING INFORMATION: BRAKE AND PARKING BRAKE CABLE KITS:

DESCRIPTION	YEAR	KIT PART NUMBERS		
		ULHP ROTOR KIT	SRP ROTOR KIT	CABLE KIT
AMC 11" Rear Kit-Black Caliper	1971 - 1974	140-11941	140-11941-D	330-11954
AMC 11" Rear Kit-Red Caliper	1971 - 1974	140-11941-R	140-11941-DR	330-11954

ORDERING INFORMATION, COMPONENTS AND SERVICE PARTS:

BASE KIT NUMBER	CALIPER	ULHP ROTOR-R/L	SRP ROTOR-R/L	BRAKE PAD AXLE SET	PARKING BRAKE MOUNT BRACKET ASSEMBLY
140-11941	120-11370	160-11364	160-11374/75-BK	150-11363K	249-11948/49