

DYNAPRO LOW-PROFILE PRO SERIES PARKING BRAKE KIT WITH 11.00" DIAMETER VENTED ROTOR

Models Covered:

Four styles of kits are available for the popular rear axles listed on page 2.

Kit Highlights:

- The newest generation of Wilwood's Pro Series rear disc brake kits with internal parking brake solves the problems associated with smaller diameter wheel clearances.
- Based on an 11.00" diameter rotor, coupled with our new DynaPro Low-Profile caliper gives you the option of a complete four piston disc brake kit with a fully functioning parking brake for 14 and 15 inch rim use (please check wheel clearance on page 2).
- Easy bolt-on installation, kits include everything necessary for a simple installation
- Compatible with OE and aftermarket disc brake master cylinders.
- It's the ultimate look in contemporary hot rod style with unmatched performance from race-born track ready components.

Component Features:

Forged DynaPro Low-Profile Calipers

- Four stainless steel pistons generate high clamping force and balanced pad loading with low heat transfer and high resistance to corrosion.
- Spring loaded stainless steel SRS bridge plates reduce noise by dampening engagement harmonics and eliminating pad rattle. SRS plates also extend caliper service life by eliminating bridge gouging at the pad trailing edge.
- Top loaded pads are easily inspected and serviced without the need to remove the caliper from the mount.
- Standard kits include black powder coat calipers. Optional red or polished calipers are also available.

SRP or HP Series 11.00" Diameter Rotors

- For cool running and increased stopping power, each kit includes 11.00" diameter vented iron alloy brake rotors with integral hats.
- Standard kits include smooth face HP rotors.
- Optional SRP directional drilled and slotted rotors enhance pad performance with consistent response by cleaning and venting gasses, dust, and burnt pad material. A black E-coat finish is applied to resist corrosion and preserve the aggressive high-tech look inside the wheel.

Wilwood BP-10 Compound High Performance "Smart Pads"

- BP-10 is an exclusive Wilwood metallic composite compound. This remarkable material possesses the quiet, low dusting properties found in ceramic based street compounds, but with the higher friction, heavier load capacity, and increased fade resistance of a medium range race pad.

Internal Shoe Parking Brake

- The drum style internal parking brake provides outstanding holding power with the ultimate uncluttered custom look.
- The two shoe system is mechanically actuated and spring loaded for quiet non-rattling performance.
- Brake shoes are neatly hidden and out-of-sight inside the rotor assembly. Parking brake cables are relocated inward with more clearance for deep offset wheels.

Mounting Brackets and Hardware

- Integral mounting brackets secure the caliper and the parking brake assembly to the axle tube.
- High strength steel and performance grade nuts, bolts, and alignment shims are include to complete the secure and accurate installation.

NOTE:

- Clevis and cable kits, which attach to the parking brake assembly are not included in the Wilwood parking brake kit. Universal and vehicle specific kits are both available. Please visit our web site at www.wilwood.com, or call (805) 388-1188 for applications for your vehicle.



Brake Kit with Optional SRP Rotor and Red Caliper
Down Load High Res Photo,
[Click Here](#)

Please check the diagram on the back of this page for minimum inside wheel clearance requirements

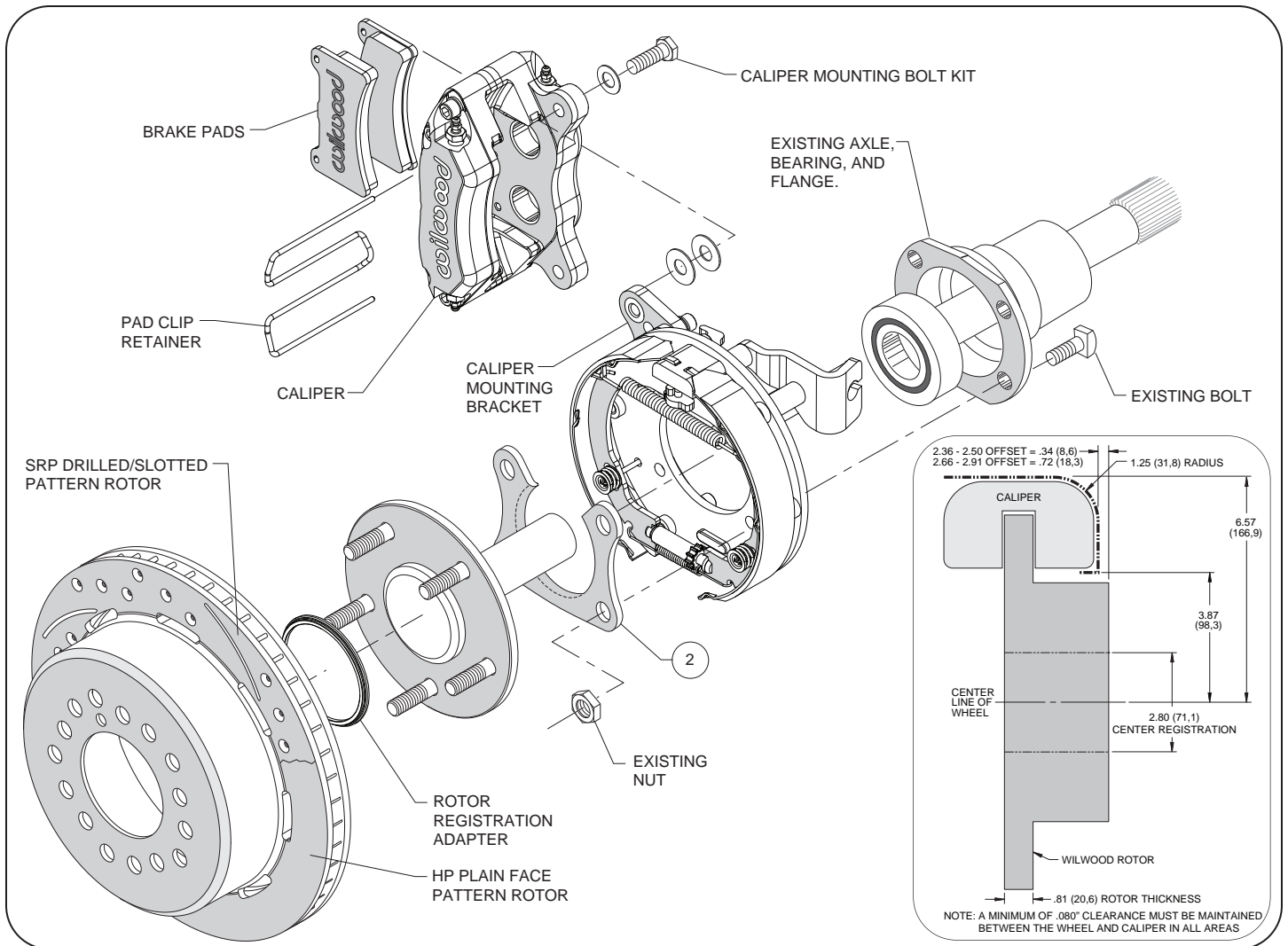

Typical Installation Diagram, Major Components Identified. Minimum Wheel Fit Dimensions Shown Lower Right Inset

ORDERING INFORMATION:

<u>BASE P/N</u>	<u>AXLE FLANGE</u>	<u>AXLE OFFSET</u>	<u>NOTE</u>	<u>BLK CALIPER HP ROTOR</u>	<u>BLK CALIPER SRP ROTOR</u>	<u>RED CALIPER HP ROTOR</u>	<u>RED CALIPER SRP ROTOR</u>
140-11385	Large Chevy C10	2.42		Yes	Yes	—	—
140-11386	Mopar/Dana	2.50		Yes	Yes	—	—
140-11387	Big Ford	2.36		Yes	Yes	Yes	Yes
140-11389	Big Ford	2.36		Yes	Yes	Yes	Yes
140-11389	Big Ford New Style	2.50		Yes	Yes	Yes	Yes
140-11390	Big Ford New Style	2.50	1	Yes	Yes	—	—
140-11392	Big Ford New Style	2.50	2	Yes	Yes	—	—
140-11393	Small Ford	2.66		Yes	Yes	—	—
140-11394	12 Bolt	2.81		Yes	Yes	Yes	Yes
140-11395	Mopar/Dana	2.36		Yes	Yes	Yes	Yes
140-11396	8.8 Ford	2.50		Yes	Yes	—	—
140-11397	Olds/Pontiac	2.81		Yes	Yes	—	—
140-11398	12 Bolt	2.75		Yes	Yes	Yes	Yes
140-11399	12 Bolt Late	2.75		Yes	Yes	Yes	Yes
140-11400	12 Bolt Special	2.81	2	Yes	Yes	—	—
140-11401	12 Bolt Special	2.81		Yes	Yes	—	—
140-11402	Big Ford New Style	2.36		Yes	Yes	Yes	Yes
140-11403	Small Ford	2.50		Yes	Yes	Yes	Yes
140-11404	Big Ford New Style	2.50	3	Yes	Yes	—	—
140-11405	55-57 Chevy	2.34		Yes	Yes	—	—

NOTES:

1. Kit comes with blank hats - no wheel bolt circle
2. Kit is designed for staggered shock mount rear ends. R/H caliper is rear mount, L/H caliper is front mount.
3. Front Mount Calipers